

HDR  
 Inco Engineering, Inc.  
 701 Kennedy Avenue  
 Minneapolis, MN 55416

ISSUE	DATE	DESCRIPTION
A	7/15/08	ENERGY FACILITY STUDY

PROJECT MANAGER	MATT CLARK
CIVIL	R. BERGERON
ELECTRICAL	J. TRAN
MECHANICAL	J. LOWE
DRAWN BY	T. LENKE
PROJECT NUMBER	87014.164

NOT FOR CONSTRUCTION

**ROCK TENN ENERGY FACILITY  
 COMBUSTION TURBINE/HEAT  
 RECOVERY STEAM GENERATOR**

**ELECTRICAL ONE-LINE DIAGRAM**

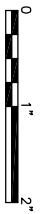

FILENAME	00E-01.dwg
SCALE	NO SCALE
SHEET	00E-01

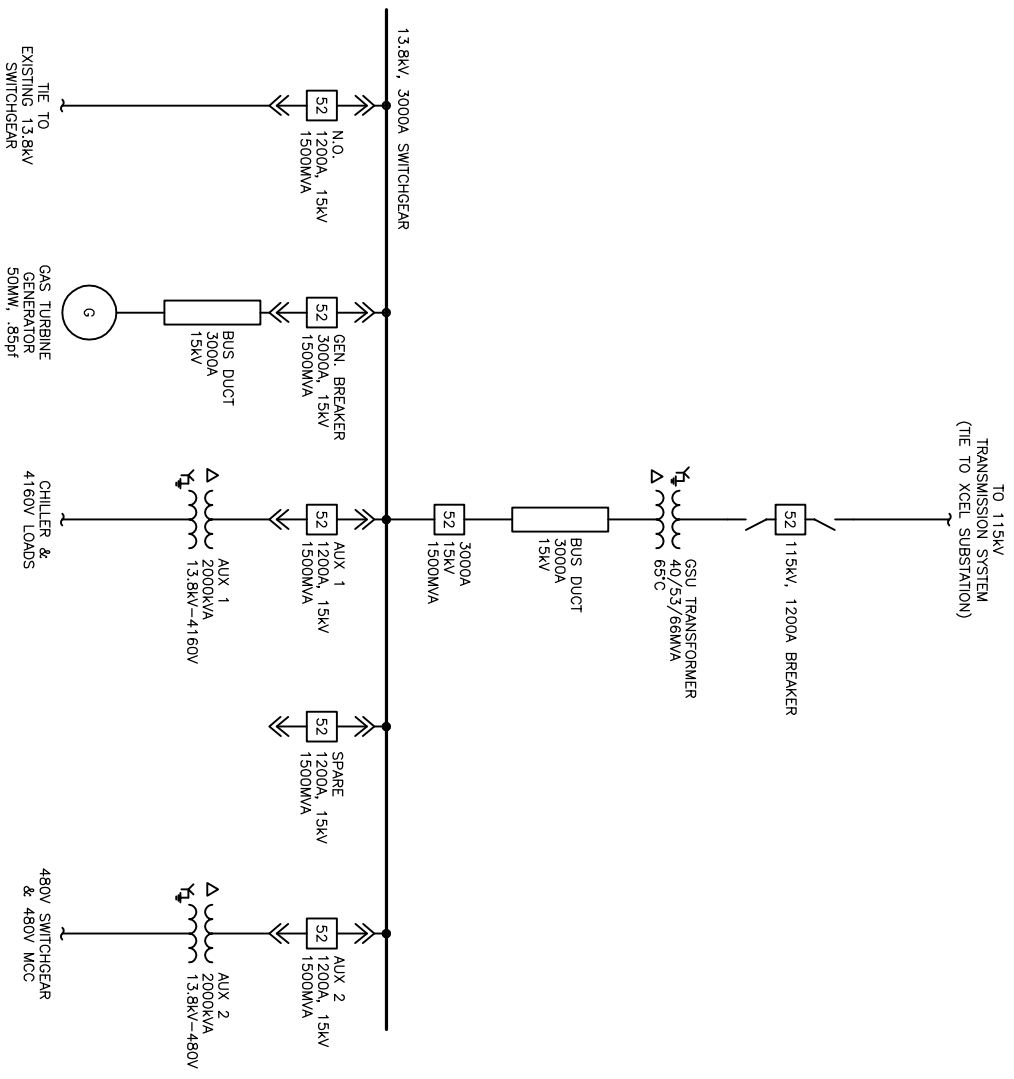

- GENERAL NOTES:**
1. INTERCONNECTION TO XCEL SUBSTATION IS TO BE DETERMINED
  2. ASSUME NEW 115kV TRANSMISSION LINE TO INTERSECT AND TIE TO EXISTING LINE BETWEEN PRIOR & MERRIAM PARK SUBSTATIONS.
  3. ALL TRANSMISSION SYSTEM WORK TO COMPLY WITH XCEL REQUIREMENTS.